

# THUMB SCREWS

## CAST

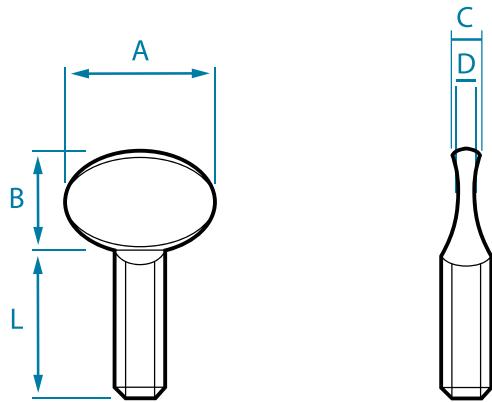

DIMENSIONS					
HEAD		M5	M6	M8	M10
	A	20,5	23,5	27,5	36,0
	B	15,5	16,0	19,0	25,0
	C	3,5	4,5	4,5	6,5
	D	2,0	2,5	2,5	3,0
		☐			
	8	-	-	-	-
	10	200	200	-	-
	12	200	200	100	-
	16	200	100	100	-
	20	200	100	100	50
LENGTH	25	-	100	100	50
	30	-	100	100	50

**PACKAGING:** Standard or according to customer specification

**MATERIAL:** Malleable cast iron, EN-GJMB-350-10 acc. to DIN EN 1562, non-plated, zinc-plated, nickel-plated acc. to DIN EN ISO 4042, further finishes on request

**TOLERANCE:** Metric thread 6 h (untreated 6 g) acc. to DIN EN ISO 965-1

All of the dimensions stated above are approximate and may deviate both upwards and downwards.

# THUMB SCREWS

## COLD FORMED

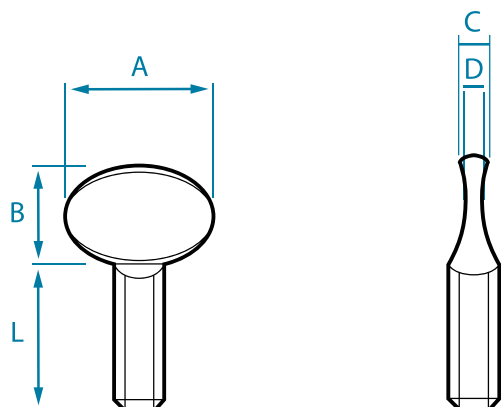

DIMENSIONS						
HEAD		M4	M5	M6	M8	M10
	A	11,2	14,0	16,5	22,0	26,0
	B	7,7	10,8	14,0	17,0	19,0
	C	2,6	3,1	4,1	4,7	6,0
	D	1,3	1,5	1,8	2,2	2,8
LENGTH	10	500	200	100	-	-
	12	200	200	100	-	-
	15	200	100	100	100	-
	20	200	100	100	100	100
	25	200	100	100	100	100
	30	200	100	-	100	100
	35	-	-	-	100	100
	40	-	-	100	100	100
	50	-	-	-	100	50
	60	-	-	-	100	20

**PACKAGING:** Standard or according to customer specification

**MATERIAL:** Steel non-plated, zinc-plated, nickel-plated acc. to DIN EN ISO 4042, further finishes on request

**TOLERANCE:** Metric thread 7 h (untreated 7 g) acc. to DIN EN ISO 965-1

All of the dimensions stated above are approximate and may deviate both upwards and downwards.